

S.S. Kutateladze

NONSTANDARD MODELS
AND
OPTIMIZATION

НОВОСИБИРСК

УДК 001.3:217.2:299.2

Дата поступления 1 июня 2008 г.

Kutateladze S. S.

NONSTANDARD MODELS AND OPTIMIZATION. — Новосибирск, 2008. — 14 с. — (Препринт / РАН. Сиб. отд-ние. Ин-т математики; № 210).

This is an overview of a few possibilities that are open by model theory in optimization. Most attention is paid to the present state and frontiers of the Cauchy method of majorants, approximation of operator equations with finite-dimensional analogs, and the Lagrange multiplier principle in multiobjective decision making.

Краткий анализ некоторых возможностей, предоставляемых теорией моделей для оптимизации. Особое внимание уделено современному состоянию и границам применимости метода мажорант Коши, приближению операторных уравнений их конечномерными аналогами и принципу множителей Лагранжа в задачах многокритериального принятия решений.

АДРЕС АВТОРА:

Институт математики им. С. Л. Соболева СО РАН
пр. Академика Коптюга, 4
630090 Новосибирск, Россия

E-MAIL: sskut@math.nsc.ru

© Кутателадзе С. С., 2008
© Институт математики
им. С. Л. Соболева СО РАН, 2008

NONSTANDARD MODELS AND OPTIMIZATION

1. Agenda

This is an overview of a few possibilities that are open by model theory in optimization. Most attention is paid to the present state and frontiers of the Cauchy method of majorants, approximation of operator equations with finite-dimensional analogs, and the Lagrange multiplier principle in multiobjective decision making. The union of functional analysis and applied mathematics celebrates its sixtieth anniversary this year.¹ The present talk focuses on the trends of interaction between model theory and the methods of domination, discretization, and scalarization.

2. The Art of Calculus

Provable counting is the art of calculus which is mathematics in modern parlance. Mathematics exists as a science more than two and a half millennia, and we can never mixed it with history or chemistry. In this respect our views of what is mathematics are independent of time. The objects of mathematics are the quantitative forms of human reasoning. Mathematics functions as the science of convincing calculations. Once-demonstrated, the facts of mathematics will never vanish. Of course, mathematics renews itself constantly, while the stock increases of mathematical notions and construction and the understanding changes of the rigor and technologies of proof and demonstration. The frontier we draw between pure and applied mathematics is also time-dependent.

3. Francis Bacon

The Mathematics are either pure or mixed. To the Pure Mathematics are those sciences belonging which handle quantity determinate, merely severed from any axioms of natural philosophy; and these are two, Geometry and Arithmetic; the one handling quantity continued, and the other dissevered. Mixed hath for subject some axioms or parts of natural philosophy, and considereth quantity determined, as it is auxiliary and incident unto them. . . . In the Mathematics. . . that use which is collateral and intervenient is no less worthy than that which is principal and intended. . . . And as for the Mixed Mathematics, I may only make this prediction, that there cannot fail to be more kinds of them, as nature grows further disclosed.

The Advancement of Learning, 1605²

¹Ср. [1, 2].

²The complete title was as follows: “The tvvoo bookes of Francis Bacon, of the proficience and aduancement of learning, diuine and humane. To the King. At London: Printed for Henrie Tomes, 1605.”

4. Mixed Turns into Applied

After the lapse of 150 years Leonhard Euler used the words “pure mathematics” in the title of one of his papers *Specimen de usu observationum in mathesi pura* in 1761. It was practically at the same time that the term “pure mathematics” had appeared in the eldest *Encyclopaedia Britannica*. In the nineteenth century “mixed” mathematics became to be referred to as “applied.”

The famous *Journal de Mathématiques Pures et Appliquées* was founded by Joseph Liouville in 1836 and *The Quarterly Journal of Pure and Applied Mathematics* started publication in 1857.

5. Pure and Applied Mathematics

The intellectual challenge, beauty, and intrinsic logic of the topics under study are the impetus of many comprehensive and deep studies in mathematics which are customarily qualified as pure. Any application of mathematics is impossible without creating some metaphors, models of the phenomena and processes under examination. Modeling is a special independent sphere of intellectual activities which is out of mathematics.

Application of mathematics resides beyond mathematics in much the same way as maladies exist in nature rather than inside medicine. Applied mathematics acts as an apothecary mixing drugs for battling illnesses.

The art and craft of mathematical techniques for the problems of other sciences are the content of applied mathematics.

6. New Challenges

Classical mechanics in the broadest sense of the words was the traditional sphere of applications of mathematics in the nineteenth century. The beginning of the twentieth century was marked with a sharp enlargement of the sphere of applications of mathematics. Quantum mechanics appeared, requesting for new mathematical tools. The theory of operators in Hilbert spaces and distribution theory were oriented to adapting the heuristic methods of the new physics. At the same time the social phenomena became the object of the nonverbal research requiring the invention of especial mathematical methods. The demand for the statistical treatment of various data grew rapidly. Founding new industries as well as introducing of promising technologies and new materials, brought about the necessity of elaboration of the technique of calculations. The rapid progress of applied mathematics was facilitated by the automation and mechanization of accounting and standard calculations.

7. Cofathers of New Mentality

In the 1930s applied mathematics rapidly approached functional analysis.

Of profound importance in this trend was the research of John von Neumann in the mathematical foundations of quantum mechanics and game theory as a tool for economic studies.

Leonid Kantorovich was a pioneer and generator of new synthetic ideas in Russia.

8. Enigmas of Economics

The main particularity of the extremal problems of economics consists in the presence of numerous conflicting ends and interests to be harmonized. We encounter the instances of multicriteria optimization. Seeking for an optimal solution in these circumstances, we must take into account various contradictory preferences which combine into a sole compound aim. It is impossible as a rule to distinguish some particular scalar target and ignore the rest of the targets. This circumstance involves the specific difficulties that are untypical in the scalar case: we must specify what we should call a solution of a vector program and we must agree upon the method of conforming versatile ends provided that some agreement is possible in principle. Therefore, it is actual to seek for the reasonable concepts of optimality in multiobjective decision making. Among these we distinguish the concepts of ideal and generalized optimum alongside Pareto-optimum as well as approximate and infinitesimal optimum.

9. Enter the Reals

Optimization is the science of choosing the best. To choose, we use preferences. To optimize, we use infima and suprema (for bounded subsets) which is practically the least upper bound property. So optimization needs ordered sets and primarily (boundedly) complete lattices.

To operate with preferences, we use group structure. To aggregate and scale, we use linear structure.

All these are happily provided by the *reals* \mathbb{R} , a one-dimensional Dedekind complete vector lattice. A Dedekind complete vector lattice is a *K-space* or *Kantorovich space* in the literature of the Russian provenance.

10. Scalarization

Scalarization in the most general sense means reduction to numbers. Since each number is a measure of quantity, the idea of scalarization is clearly of a universal importance to mathematics. The deep roots of scalarization are revealed by the Boolean valued validation of the Kantorovich heuristic principle. We will dwell upon the aspects of scalarization most important in applications and connected with the problems of multicriteria optimization.

11. Legendre in Disguise

Assume that X is a vector space, E is an ordered vector space, $f : X \rightarrow E^\bullet := E \cup +\infty$ is a convex operator, and $C := \text{dom}(f) \subset X$ is a convex set. A *vector program* (C, f) is written as follows:

$$x \in C, \quad f(x) \rightarrow \inf.$$

The standard sociological trick includes (C, f) into a parametric family yielding the *Legendre transform* or *Young–Fenchel transform* of f :

$$f^*(l) := \sup_{x \in X} (l(x) - f(x)),$$

with $l \in X^\#$ a linear functional over X . The epigraph of f^* is a convex subset of $X^\#$ and so f^* is convex. Observe that $-f^*(0)$ is the value of (C, f) .

12. Order Omnipresent

A convex function is locally a positively homogeneous convex function, a *sublinear functional*. Recall that $p : X \rightarrow \mathbb{R}$ is sublinear whenever

$$\text{epi } p := \{(x, t) \in X \times \mathbb{R} : p(x) \leq t\}$$

is a cone. Recall that a numeric function is uniquely determined from its epigraph.

Given $C \subset X$, put

$$H(C) := \{(x, t) \in X \times \mathbb{R}^+ : x \in tC\},$$

the *Hörmander transform* of C . Now, C is convex if and only if $H(C)$ is a cone. A space with a cone is a *(pre)ordered vector space*.

Leibniz remarked wittily: *The order, the symmetry, the harmony enchant us. . . .*

13. Fermat's Criterion

$\partial f(\bar{x})$, the *subdifferential* of f at \bar{x} , is

$$\{l \in X^\# : (\forall x \in X) l(x) - l(\bar{x}) \leq f(x) - f(\bar{x})\}.$$

A point \bar{x} is a solution to the minimization problem (X, f) if and only if

$$0 \in \partial f(\bar{x}).$$

This *Fermat criterion* turns into the Rolle Theorem in a smooth case and is of little avail without effective tools for calculating $\partial f(\bar{x})$. A convex analog of the “chain rule” is in order.

14. Enter Hahn–Banach

The *Dominated Extension* takes the form

$$\partial(p \circ \iota)(0) = (\partial p)(0) \circ \iota,$$

with p a sublinear functional over X and ι the identical embedding of some subspace of X into X .

If the target \mathbb{R} may be replaced with an ordered vector space E , then E admits *dominated extension*.

15. Enter Kantorovich

The matching of convexity and order was established in two steps.

Hahn–Banach–Kantorovich Theorem. *Every Kantorovich space admits dominated extension of linear operators.*

This theorem proven by Kantorovich in 1935 was a first attractive result of the theory of ordered vector spaces.

Bonnice–Silvermann–To Theorem. *Each ordered vector space admitting dominated extension of linear operators is a Kantorovich space.*

16. New Heuristics

Kantorovich demonstrated the role of K -spaces by the example of the Hahn–Banach theorem. He proved that this central principle of functional analysis admits the replacement of reals with elements of an arbitrary K -space while substituting linear and sublinear operators with range in this space for linear and sublinear functionals. These observations laid grounds for the universal heuristics based on his intuitive belief that the members of an abstract Kantorovich space are a sort of generalized numbers.

17. Canonical Operator

Consider a Kantorovich space E and an arbitrary nonempty set \mathfrak{A} . Denote by $l_\infty(\mathfrak{A}, E)$ the set of all order bounded mappings from \mathfrak{A} into E ; i.e., $f \in l_\infty(\mathfrak{A}, E)$ if and only if $f : \mathfrak{A} \rightarrow E$ and $\{f(\alpha) : \alpha \in \mathfrak{A}\}$ is order bounded in E . It is easy to verify that $l_\infty(\mathfrak{A}, E)$ becomes a Kantorovich space if endowed with the coordinatewise algebraic operations and order. The operator $\varepsilon_{\mathfrak{A}, E}$ acting from $l_\infty(\mathfrak{A}, E)$ into E by the rule

$$\varepsilon_{\mathfrak{A}, E} : f \mapsto \sup\{f(\alpha) : \alpha \in \mathfrak{A}\} \quad (f \in l_\infty(\mathfrak{A}, E))$$

is called the *canonical sublinear operator* given \mathfrak{A} and E . We often write $\varepsilon_{\mathfrak{A}}$ instead of $\varepsilon_{\mathfrak{A}, E}$ when it is clear from the context what Kantorovich space is meant. The notation ε_n is used when the cardinality of \mathfrak{A} equals n and we call the operator ε_n *finitely-generated*.

18. Support Hull

Consider a set \mathfrak{A} of linear operators acting from a vector space X into a Kantorovich space E . The set \mathfrak{A} is *weakly order bounded* if $\{\alpha x : \alpha \in \mathfrak{A}\}$ is order bounded for every $x \in X$. We denote by $\langle \mathfrak{A} \rangle x$ the mapping that assigns the element $\alpha x \in E$ to each $\alpha \in \mathfrak{A}$, i.e. $\langle \mathfrak{A} \rangle x : \alpha \mapsto \alpha x$. If \mathfrak{A} is weakly order bounded then $\langle \mathfrak{A} \rangle x \in l_\infty(\mathfrak{A}, E)$ for every fixed $x \in X$. Consequently, we obtain the linear operator $\langle \mathfrak{A} \rangle : X \rightarrow l_\infty(\mathfrak{A}, E)$ that acts as $\langle \mathfrak{A} \rangle : x \mapsto \langle \mathfrak{A} \rangle x$. Associate with \mathfrak{A} one more operator

$$p_{\mathfrak{A}} : x \mapsto \sup\{\alpha x : \alpha \in \mathfrak{A}\} \quad (x \in X).$$

The operator $p_{\mathfrak{A}}$ is sublinear. The support set $\partial p_{\mathfrak{A}}$ is denoted by $\text{cop}(\mathfrak{A})$ and referred to as the *support hull* of \mathfrak{A} .

19. Hahn–Banach in Disguise

Theorem. *If p is a sublinear operator with $\partial p = \text{cop}(\mathfrak{A})$ then $P = \varepsilon_{\mathfrak{A}} \circ \langle \mathfrak{A} \rangle$. Assume further that $p_1 : X \rightarrow E$ is a sublinear operator and $p_2 : E \rightarrow F$ is an increasing sublinear operator. Then*

$$\partial(p_2 \circ p_1) = \{T \circ \langle \partial p_1 \rangle : T \in L^+(l_\infty(\partial p_1, E), F) \& T \circ \Delta_{\partial p_1} \in \partial p_2\}.$$

Moreover, if $\partial p_1 = \text{cop}(\mathfrak{A}_1)$ and $\partial p_2 = \text{cop}(\mathfrak{A}_2)$ then

$$\partial(p_2 \circ p_1) = \{T \circ \langle \mathfrak{A}_1 \rangle : T \in L^+(l_\infty(\mathfrak{A}_1, E), F) \ (\exists \alpha \in \partial \varepsilon_{\mathfrak{A}_2}) \ T \circ \Delta_{\mathfrak{A}_1} = \alpha \circ \langle \mathfrak{A}_2 \rangle\}.$$

20. Enter Boole

Cohen's final solution of the problem of the cardinality of the continuum within ZFC gave rise to the Boolean valued models by Vopěnka, Scott, and Solovay. Takeuti coined the term "Boolean valued analysis" for applications of the new models to functional analysis.

Let B be a complete Boolean algebra. Given an ordinal α , put

$$V_\alpha^{(B)} := \{x : (\exists \beta \in \alpha) x : \text{dom}(x) \rightarrow B \ \& \ \text{dom}(x) \subset V_\beta^{(B)}\}.$$

The *Boolean valued universe* $\mathbb{V}^{(B)}$ is

$$\mathbb{V}^{(B)} := \bigcup_{\alpha \in \text{On}} V_\alpha^{(B)},$$

with On the class of all ordinals. The truth value $\llbracket \varphi \rrbracket \in B$ is assigned to each formula φ of ZFC relativized to $\mathbb{V}^{(B)}$.

21. Enter Descent

Given φ , a formula of ZFC, and y , a subset $\mathbb{V}^{(B)}$; put $A_\varphi := A_{\varphi(\cdot, y)} := \{x : \varphi(x, y)\}$. The *descent* $A_\varphi \downarrow$ of a class A_φ is

$$A_\varphi \downarrow := \{t : t \in \mathbb{V}^{(B)} \ \& \ \llbracket \varphi(t, y) \rrbracket = \mathbb{1}\}.$$

If $t \in A_\varphi \downarrow$, then it is said that t *satisfies* $\varphi(\cdot, y)$ *inside* $\mathbb{V}^{(B)}$.

The *descent* $x \downarrow$ of an element $x \in \mathbb{V}^{(B)}$ is defined by the rule

$$x \downarrow := \{t : t \in \mathbb{V}^{(B)} \ \& \ \llbracket t \in x \rrbracket = \mathbb{1}\},$$

i.e. $x \downarrow = A_{\in x} \downarrow$. The class $x \downarrow$ is a set. Moreover, $x \downarrow \subset \text{mix}(\text{dom}(x))$, where mix is the symbol of the taking of the *strong cyclic hull*. If x is a nonempty set inside $\mathbb{V}^{(B)}$ then

$$(\exists z \in x \downarrow) \llbracket (\exists z \in x) \varphi(z) \rrbracket = \llbracket \varphi(z) \rrbracket.$$

22. The Reals in Disguise

There is an object \mathcal{R} inside $\mathbb{V}^{(B)}$ modeling \mathbb{R} , i.e.,

$$\llbracket \mathcal{R} \text{ is the reals} \rrbracket = \mathbb{1}.$$

Let $\mathcal{R} \downarrow$ be the descent of the carrier $|\mathcal{R}|$ of the algebraic system $\mathcal{R} := (|\mathcal{R}|, +, \cdot, 0, 1, \leq)$ inside $\mathbb{V}^{(B)}$. Implement the descent of the structures on $|\mathcal{R}|$ to $\mathcal{R} \downarrow$ as follows:

$$\begin{aligned} x + y = z &\leftrightarrow \llbracket x + y = z \rrbracket = \mathbb{1}; \quad xy = z \leftrightarrow \llbracket xy = z \rrbracket = \mathbb{1}; \\ x \leq y &\leftrightarrow \llbracket x \leq y \rrbracket = \mathbb{1}; \quad \lambda x = y \leftrightarrow \llbracket \lambda^\wedge x = y \rrbracket = \mathbb{1} \\ &(x, y, z \in \mathcal{R} \downarrow, \lambda \in \mathbb{R}). \end{aligned}$$

Gordon Theorem. $\mathcal{R} \downarrow$ with the descended structures is a universally complete Kantorovich space with base $\mathcal{B}(\mathcal{R} \downarrow)$ isomorphic to B .

23. Norming Sequences

$$\mathbf{||}(\xi_1, \xi_2, \dots)\mathbf{||} = (|\xi_1|, |\xi_2|, \dots, |\xi_{N-1}|, \sup_{k \geq N} |\xi_k|) \in \mathbb{R}^N.$$

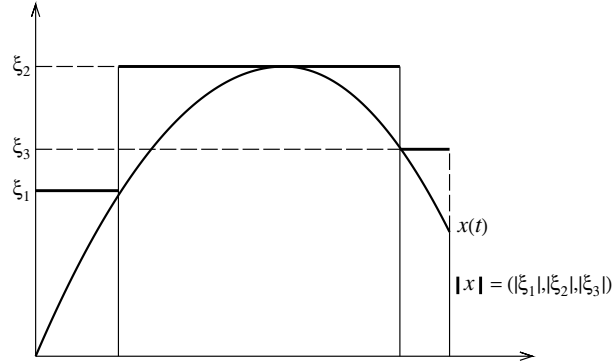

I believe that the use of members of semioordered linear spaces instead of reals in various estimations can lead to essential improvement of the latter.

Kantorovich (1948)³

24. Domination

Let X and Y be real vector spaces lattice-normed with K -spaces E and F . In other words, given are some lattice-norms $\mathbf{||}\cdot\mathbf{||}_X$ and $\mathbf{||}\cdot\mathbf{||}_Y$. Assume further that T is a linear operator from X to Y and S is a positive operator from X into Y satisfying

$$\begin{array}{ccc} X & \xrightarrow{T} & Y \\ \mathbf{||}\cdot\mathbf{||}_X \downarrow & & \downarrow \mathbf{||}\cdot\mathbf{||}_Y \\ E & \xrightarrow{S} & F \end{array}$$

Moreover, in case $\mathbf{||}Tx\mathbf{||}_Y \leq S\mathbf{||}x\mathbf{||}_X$ ($x \in X$), we call S the *dominant* or *majorant* of T .

25. Enter Abstract Norm

If the set of all dominants of T has the least element, then the latter is called the *abstract norm* or *least dominant* of T and denoted by $\mathbf{||}T\mathbf{||}$. Hence, the least dominant $\mathbf{||}T\mathbf{||}$ is the least positive operator from E to F such that $\mathbf{||}Tx\mathbf{||} \leq \mathbf{||}T\mathbf{||}(\mathbf{||}x\mathbf{||})$ ($x \in X$).

26. Domination and Model Theory

These days the development of domination proceeds within the frameworks of Boolean valued analysis. All principal properties of lattice normed spaces represent the Boolean valued interpretations of the relevant properties of classical normed spaces. The most important interrelations here are as follows: Each Banach space inside a Boolean valued model becomes a universally complete Banach–Kantorovich space in result of the external deciphering of constituents. Moreover, each lattice normed space may be realized as

³Cp. [1].

a dense subspace of some Banach space in an appropriate Boolean valued model. Finally, a Banach space X results from some Banach space inside a Boolean valued model by a special machinery of bounded descent if and only if X admits a complete Boolean algebra of norm-one projections which enjoys the cyclicity property. The latter amounts to the fact that X is a Banach–Kantorovich space and X is furnished with a mixed norm.

27. Approximation

Convexity is an abstraction of finitely many stakes encircled with a surrounding rope, and so no variation of stakes can ever spoil the convexity of the tract to be surveyed.

Study of stability in optimization is accomplished sometimes by introducing various epsilons in appropriate places. One of the earliest excursions in this direction is connected with the classical Hyers–Ulam stability theorem for ε -convex functions. Exact calculations with epsilons and sharp estimates are sometimes bulky and slightly mysterious. Some alternatives are suggested by actual infinities, which is illustrated with the conception of *infinitesimal optimality*.

28. Enter Epsilon and Monad

Assume given a convex operator $f : X \rightarrow E \cup +\infty$ and a point \bar{x} in the effective domain $\text{dom}(f) := \{x \in X : f(x) < +\infty\}$ of f . Given $\varepsilon \geq 0$ in the positive cone E_+ of E , by the ε -subdifferential of f at \bar{x} we mean the set

$$\partial^\varepsilon f(\bar{x}) := \{T \in L(X, E) : (\forall x \in X)(Tx - Fx \leq T\bar{x} - f\bar{x} + \varepsilon)\},$$

with $L(X, E)$ standing as usual for the space of linear operators from X to E .

Distinguish some downward-filtered subset \mathcal{E} of E that is composed of positive elements. Assuming E and \mathcal{E} standard, define the *monad* $\mu(\mathcal{E})$ of \mathcal{E} as $\mu(\mathcal{E}) := \bigcap \{[0, \varepsilon] : \varepsilon \in \mathcal{E}\}$. The members of $\mu(\mathcal{E})$ are *positive infinitesimals* with respect to \mathcal{E} . As usual, ${}^\circ\mathcal{E}$ denotes the external set of all standard members of E , the *standard part* of \mathcal{E} .

29. Pareto Optimality

Fix a positive element $\varepsilon \in E$. A feasible point x_0 is a ε -solution or ε -optimum of a program (C, f) provided that $f(x_0) \leq e + \varepsilon$ with e the value of (C, f) . In other words, x_0 is an ε -solution of (C, f) if and only if $x_0 \in C$ and $f(x_0) - \varepsilon$ is the greatest lower bound of $f(C)$ or, equivalently, $f(C) + \varepsilon \subset f(x_0) + E^+$. Clearly, x_0 is an ε -solution of an unconditional problem $f(x) \rightarrow \inf$ if and only if the zero belongs to $\partial^\varepsilon f(x_0)$; i.e.,

$$f(x_0) \leq \inf_{x \in X} f(x) + \varepsilon \leftrightarrow 0 \in \partial^\varepsilon f(x_0).$$

30. Approximate Efficiency

A feasible point x_0 is ε -Pareto optimal for (C, f) whenever $f(x_0)$ is a minimal element of $U + \varepsilon$, with $U := f(C)$; i.e., $(f(x_0) - E^+) \cap (f(C) + \varepsilon) = [f(x_0)]$. In more detail, x_0 is ε -Pareto-optimal means that $x_0 \in C$ and, for all $x \in C$, from $f(x_0) \geq f(x) + \varepsilon$ it follows that $f(x_0) \sim f(x) + \varepsilon$.

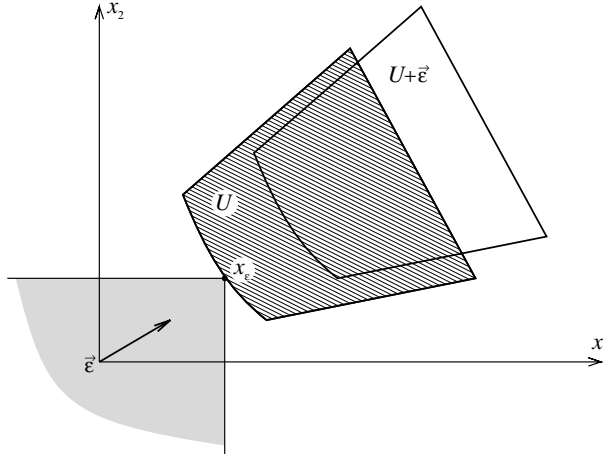

31. Subdifferential Halo

Assume that the monad $\mu(\mathcal{E})$ is an external cone over ${}^\circ\mathbb{R}$ and, moreover, $\mu(\mathcal{E}) \cap {}^\circ E = 0$. In application, \mathcal{E} is usually the filter of order-units of E . The relation of *infinite proximity* or *infinite closeness* between the members of E is introduced as follows:

$$e_1 \approx e_2 \leftrightarrow e_1 - e_2 \in \mu(\mathcal{E}) \ \& \ e_2 - e_1 \in \mu(\mathcal{E}).$$

Now

$$Df(\bar{x}) := \bigcap_{\varepsilon \in {}^\circ\mathcal{E}} \partial^\varepsilon f(\bar{x}) = \bigcup_{\varepsilon \in \mu(\mathcal{E})} \partial^\varepsilon f(\bar{x});$$

the *infinitesimal subdifferential* of f at \bar{x} . The elements of $Df(\bar{x})$ are *infinitesimal subgradients* of f at \bar{x} .

32. Exeunt Epsilon

Theorem. Let $f_1 : X \times Y \rightarrow E \cup +\infty$ and $f_2 : Y \times Z \rightarrow E \cup +\infty$ be convex operators. Suppose that the convolution $f_2 \Delta f_1$ is infinitesimally exact at some point (x, y, z) ; i.e., $(f_2 \Delta f_1)(x, y) \approx f_1(x, y) + f_2(y, z)$. If, moreover, the convex sets $\text{epi}(f_1, Z)$ and $\text{epi}(X, f_2)$ are in general position then

$$D(f_2 \Delta f_1)(x, y) = Df_2(y, z) \circ Df_1(x, y).$$

33. Discretization

It seems to me that the main idea of this theory is of a general character and reflects the general gnoseological principle for studying complex systems. It was, of course, used earlier, and it is also used in systems analysis, but it does not have a rigorous mathematical apparatus.

The principle consists simply in the fact that to a given large complex system in some space a simpler, smaller dimensional model in this or a simpler space is associated by means of one-to-one or one-to-many correspondence. The study of this simplified model turns out, naturally, to be simpler and more practicable. This method, of course, presents definite requirements on the quality of the approximating system.

Kantorovich (1948)⁴

⁴Cp. [1].

34. Hypodiscretization

The analysis of the equation $Tx = y$, with $T : X \rightarrow Y$ a bounded linear operator between some Banach spaces X and Y , consists in choosing finite-dimensional vector spaces X_N and Y_N and the corresponding embeddings ι_N and J_N :

$$\begin{array}{ccc} X & \xrightarrow{T} & Y \\ \iota_N \uparrow & & \uparrow J_N \\ X_N & \xrightarrow{T_N} & Y_N \end{array}$$

In this event, the equation $T_N x_N = y_N$ is viewed as a finite-dimensional approximation to the original problem.

35. Hyperdiscretization

Nonstandard models yield the method of hyperapproximation

$$\begin{array}{ccc} E & \xrightarrow{T} & F \\ \varphi_E \downarrow & & \downarrow \varphi_F \\ E^\# & \xrightarrow{T^\#} & F^\# \end{array}$$

Here E and F are normed spaces over the same scalars, while T is a bounded linear operator from E to F , and $\#$ symbolizes a nonstandard hull.

36. The Hull of a Space

Let $*$ be the symbol of the Robinsonian standardization. Let $(E, \|\cdot\|)$ be an internal normed space over ${}^*\mathbb{F}$, with $\mathbb{F} := \mathbb{R}; \mathbb{C}$. As usual, $x \in E$ is a *limited* element provided that $\|x\|$ is a limited real (whose modulus has a standard upper bound by definition). If $\|x\|$ is an infinitesimal then x is also referred to as an *infinitesimal*. Denote by $\text{ltd}(E)$ and $\mu(E)$ the external sets of limited elements and infinitesimals of E . The set $\mu(E)$ is the *monad* of the origin in E . Clearly, $\text{ltd}(E)$ is an external vector space over \mathbb{F} , and $\mu(E)$ is a subspace of $\text{ltd}(E)$. Put $E^\# = \text{ltd}(E)/\mu(E)$ and endow $E^\#$ with the natural norm $\|\varphi x\| := \|x^\#\| := \text{st}(\|x\|) \in \mathbb{F}$ for all $x \in \text{ltd}(E)$. Here $\varphi := \varphi_E := (\cdot)^\# : \text{ltd}(E) \rightarrow E^\#$ is the canonical homomorphism, and st takes the standard part of a limited real. This $(E^\#, \|\cdot\|)$ is an external normed space called the *nonstandard hull* of E .

37. The Hull of an Operator

Suppose now that E and F are internal normed spaces and $T : E \rightarrow F$ is an internal bounded linear operator. The set of reals

$$c(T) := \{C \in {}^*\mathbb{R} : (\forall x \in E) \|Tx\| \leq C\|x\|\}$$

is internal and bounded.

Recall that

$$\|T\| := \inf c(T).$$

If the norm $\|T\|$ of T is limited then the classical normative inequality $\|Tx\| \leq \|T\| \|x\|$ valid for all $x \in E$, implies that $T(\text{ltd}(E)) \subset \text{ltd}(F)$ and $T(\mu(E)) \subset \mu(F)$. Hence, we may soundly define the descent of T to the factor space $E^\#$ as the external operator $T^\# : E^\# \rightarrow F^\#$, acting by the rule

$$T^\# \varphi_E x := \varphi_F T x \quad (x \in E).$$

The operator $T^\#$ is linear (with respect to the members of \mathbb{F}) and bounded; moreover, $\|T^\#\| = \text{st}(\|T\|)$. The operator $T^\#$ is called the *nonstandard hull* of T .

38. One Puzzling Definition

Approximation of arbitrary function spaces and operators by their finite-dimensional analogs, which is *discretization*, matches the marvelous universal understanding of computational mathematics as the science of finite approximations to general (not necessarily metrizable) compacta. This revolutionary and challenging definition was given in the joint talk submitted by S. L. Sobolev, L. A. Lyusternik, and L. V. Kantorovich at the Third All-Union Mathematical Congress in 1956.

Infinitesimal methods suggest a background, providing new schemes for hyperapproximation of general compact spaces. As an approximation to a compact space we may take an arbitrary internal subset containing all standard elements of the space under approximation.

39. State of the Art

Adaptation of the ideas of model theory to optimization projects among the most important directions of developing the synthetic methods of pure and applied mathematics. This approach yields new models of numbers, spaces, and types of equations. The content expands of all available theorems and algorithms. The whole methodology of mathematical research is enriched and renewed, opening up absolutely fantastic opportunities. We can now use actual infinities and infinitesimals, transform matrices into numbers, spaces into straight lines, and noncompact spaces into compact spaces, yet having still uncharted vast territories of new knowledge.

40. Vistas of the Future

Quite a long time had passed until the classical functional analysis occupied its present position of the language of continuous mathematics. Now the time has come of the new powerful technologies of model theory in mathematical analysis. Not all theoretical and applied mathematicians have already gained the importance of modern tools and learned how to use them. However, there is no backward traffic in science, and the new methods are doomed to reside in the realm of mathematics for ever and in a short time they will become as elementary and omnipresent in calculus and calculations as Banach spaces and linear operators.

СПИСОК ЛИТЕРАТУРЫ

- [1] L. V. Kantorovich, “Functional Analysis and Applied Mathematics,” *Vestnik Leningrad Univ. Mat.* **6**, 3–18 (1948).
- [2] L. V. Kantorovich, “Functional Analysis and Applied Mathematics,” *Uspekhi Mat. Nauk* **3** (6), 3–50 (1948).
- [3] L. V. Kantorovich, “On Semioordered Linear Spaces and Their Applications in the Theory of Linear Operators,” *Dokl. Akad. Nauk SSSR* **4** (1–2), 11–14 (1935).
- [4] L. V. Kantorovich, “The Principle of Majorants and the Newton Method,” *Dokl. Akad. Nauk SSSR* **76** (1), 17–20 (1951).
- [5] S. L. Sobolev, L. A. Lyusternik, and L. V. Kantorovich, “Functional Analysis and Computational Mathematics,” in *Proceedings of the Third All-Union Mathematical Congress*, Moscow, June–July 1956 (Moscow, 1956), Vol. 2, p. 43 [in Russian].
- [6] L. V. Kantorovich, “Functional Analysis (the Main Ideas),” *Sibirsk. Mat. Zh.* **28** (1), pp. 7–16 (1987).
- [7] Kantorovich L. V. “My Way in Science”// *Uspekhi Mat. Nauk*, **48** 2. 183–213 (1987).
- [8] L. V. Kantorovich, *Selected Works. Part I. Descriptive Theory of Sets and Functions. Functional Analysis in Semi-ordered Spaces* (Gordon and Breach Publishers, Amsterdam, 1996).
- [9] L. V. Kantorovich, *Selected Works. Part II. Applied Functional Analysis. Approximation Methods and Computers* (Gordon and Breach Publishers, Amsterdam, 1996).
- [10] A. G. Kusraev, *Dominated Operators* (Kluwer Academic Publishers, Dordrecht, 2001; Nauka, Moscow, 2003).
- [11] A. G. Kusraev and S. S. Kutateladze, *Introduction to Boolean Valued Analysis* (Nauka, Moscow, 2005) [in Russian].
- [12] S. S. Kutateladze, “Convex Operators,” *Uspekhi Mat. Nauk* **34** (1), pp. 167–196 (1979).
- [13] S. S. Kutateladze, “Convex ε -Programming,” *Dokl. Akad. Nauk SSSR* **245** (5), pp. 1048–1050 (1979).
- [14] S. S. Kutateladze, “A Version of Nonstandard Convex Programming,” *Sibirsk. Mat. Zh.* **27** (4), pp. 84–92 (1986).
- [15] A. G. Kusraev and S. S. Kutateladze, *Subdifferential Calculus: Theory and Applications* (Nauka, Moscow, 2007) [in Russian].
- [16] E. I. Gordon, A. G. Kusraev, and S. S. Kutateladze, *Infinitesimal Analysis: Selected Topics* (Nauka, Moscow, 2008) [in Russian].
- [17] C. Zalinescu, *Convex Analysis in General Vector Spaces* (World Scientific Publishers, London, 2002).
- [18] I. Singer, *Abstract Convex Analysis* (John Wiley & Sons, New York, 1997).
- [19] G. Y. Chen, X. Huang, and X. Yang, *Vector Optimization. Set-Valued and Variational Analysis* (Springer-Verlag, Berlin, 2005) (*Lecture Notes in Economics and Mathematical Systems*, Vol. 541).
- [20] P. Loridan, “ ε -Solutions in Vector Minimization Problems,” *J. Optim. Theory Appl.* **43** (3), 265–276 (1984).
- [21] I. Valyi, “Approximate Saddle-Point Theorems in Vector Optimization,” *J. Optim. Theory Appl.* **55**, 435–448 (1987).
- [22] J. C. Liu, “ ε -Duality Theorem of Nondifferentiable Nonconvex Multiobjective Programming,” *J. Optim. Theory Appl.* **69** (1), 153–167 (1991).
- [23] J. C. Liu and K. Yokoyama, “ ε -Optimality and Duality for Multiobjective Fractional Programming,” *Comput. Math. Appl.* **37** (8), 119–128 (1999).
- [24] J. C. Liu, “ ε -Properly Efficient Solutions to Nondifferentiable Multiobjective Programming Problems,” *Appl. Math. Lett.* **12** (6), 109–113 (1999).
- [25] C. Gutiérrez, B. Jiménez, and V. Novo, “On Approximate Solutions in Vector Optimization Problems via Scalarization,” *Comput. Optim. Appl.* **35** (3), 305–324 (2006).
- [26] C. Gutiérrez, B. Jiménez, and V. Novo, “Optimality Conditions for Metrically Consistent Approximate Solutions in Vector Optimization,” *J. Optim. Theory Appl.* **133** (1), 49–64 (2007).

Кутателадзе Семён Самсонович

NONSTANDARD MODELS AND OPTIMIZATION

Препринт № 210

Ответственный за выпуск
академик Ю. Г. Решетняк

Издание подготовлено с использованием макропакета $\mathcal{A}\mathcal{M}\mathcal{S}$ - $\text{T}\mathcal{E}\mathcal{X}$,
разработанного Американским математическим обществом

This publication was typeset using $\mathcal{A}\mathcal{M}\mathcal{S}$ - $\text{T}\mathcal{E}\mathcal{X}$,
the American Mathematical Society's $\text{T}\mathcal{E}\mathcal{X}$ macro package

Подписано в печать 14.02.08. Формат $60 \times 84^{1/8}$.
Усл. печ. л. 3,5. Уч.-изд. л. 3,5. Тираж 75 экз. Заказ № 28.

Отпечатано в ООО «Омега Принт»
пр. Академика Лаврентьева, 6, 630090 Новосибирск